

DS20-S-01

OPERATING MANUAL

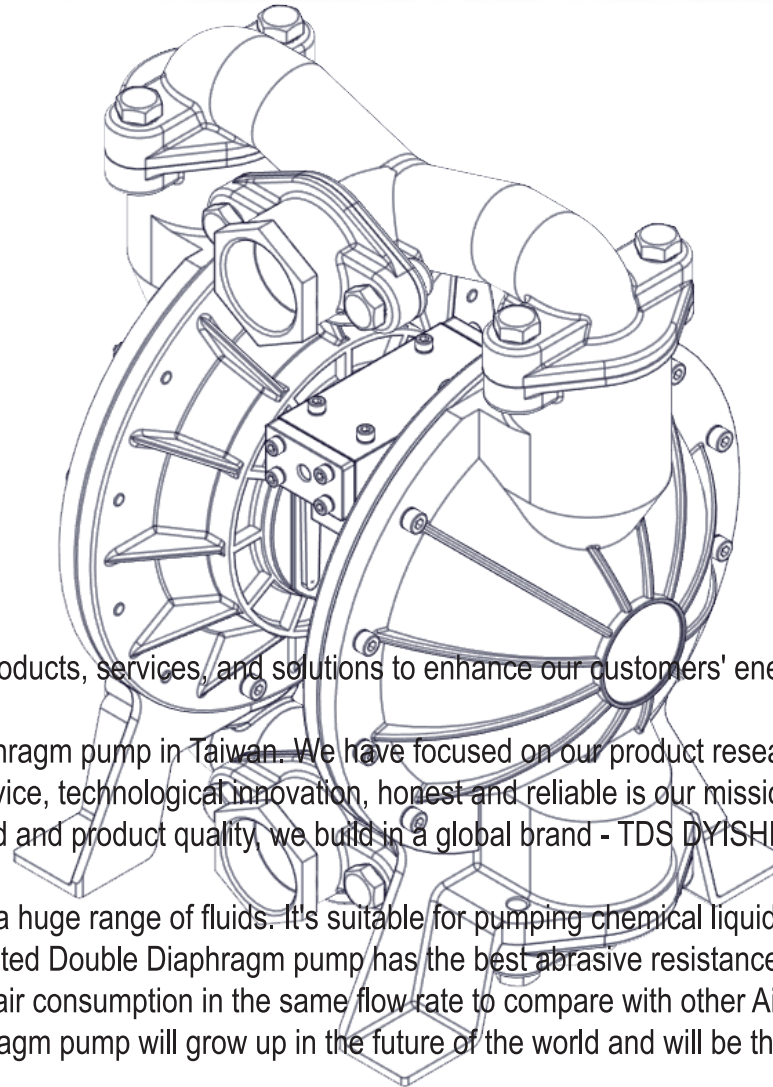

COMPANY PROFILE

DYI SHENG Industry Co., Ltd. was established in 1986. We provide products, services, and solutions to enhance our customers' energy efficiency, productivity, and operation.

We are the professional manufacturer of an Air-Operated Double Diaphragm pump in Taiwan. We have focused on our product research and development. Now we have CE, ATEX, and ISO9001 quality certifications. Being high quality, quick service, technological innovation, honest and reliable is our mission statement. We have been sold our products for more than 20 years all over the world. To protect our brand and product quality, we build in a global brand - TDS DYISHENG after 2011.

An Air-Operated Double Diaphragm pump is a versatile workhorse for a huge range of fluids. It's suitable for pumping chemical liquids, food sauce, industrial sludge, and any liquids with solid particles or impurity. Our TDS DYISHENG - Air-Operated Double Diaphragm pump has the best abrasive resistance about air valve design. We also have a Non-stall patent of pumps in the world. This design can save 15~20% air consumption in the same flow rate to compare with other Air-Operated Double Diaphragm pumps. We believe deeply that TDS DYISHENG - Air-Operated Double Diaphragm pump will grow up in the future of the world and will be the quality certificate of the whole world.

INDEX

Index.....	1
Type Specification Indication.....	2
Pump Type and Liquids Serviceability Specification.....	3
Material and Temperature Range.....	4
Exploded View Drawing.....	5
Screws Torque Guide.....	6
Dimensions.....	7
Important Safety Information.....	8
Installation Considerations.....	9
Installation Instructions.....	10
FAQ.....	11
Warranty Instructions.....	12



Important

Read these instructions completely, before installation and start-up. It is the responsibility of the purchaser to retain this manual for reference. Failure to comply with the recommendations stated in this manual will damage the pump and void the factory warranty.

TYPE SPECIFICATION INDICATION

According to your demands, you can follow the explanation below.

DSXX-XXX-XXXX-XX

Size	Wetted Body	Center Body	Pupe Type	Diaphragm	Ball cover	Ball	Ball seat	Edition
20 : 2"	S : Stainless Steel (SUS316)	A : Aluminum	T : Conter	O : Santoprene	S : Stainless Steel	S : S.S #316	P : PP	01
						T : PTFE	S : Stainless Steel	
						B : Bakelite	T : PTFE	
						N : NBR		

※ Note: PPG-Polypropylene add Bolivian filament ent
 This is for reference only; the actual specifications should contact our sales.



Important

Read these instructions completely, before installation and start-up. It is the responsibility of the purchaser to retain this manual for reference. Failure to comply with the recommendations stated in this manual will damage the pump and void the factory warranty.

PUMP TYPE AND LIQUIDS SERVICEABILITY SPECIFICATION

Pump Type	Liquids Serviceability
DSXX-AAx-UXXX-X	Paint, Solvent, Ink, Glue, Pulp, Heavy Oil, Toluene, Benzene
DSXX-AAx-TXXX-X	High temperature liquid, Resin, Metal Scrap Solution, Gasoline, Xylene, Acetone
DSXX-AAx-OXXX-X	Mud, Sludge, Waste Water, Lubrication Oil, Motor Oil, Cutting Oil, Turbine Oil, Methyl Alcohol, Release Agent, Casting Fluid
DSXX-PXX-OXXX-X	Seawater, Hydrogen Peroxide Solution, Acid and Alkali, Floats the Clean Water
DSXX-PXX-TXXX-X	Inferior Sodium Nitrite, Hydrochloric Acid, Aqua Regia, Phosphoric Acid, Boric Acid, Liquid Medicine
DSXX-SXX-UXXX-X	Glycol, Alcohol, Sodium Hydroxide, Nitric Acid, Carbonic Acid, Fruit Acid, Enzyme, Sodium Nitrate, Ethanol, Citric Acid, Wastewater, Liquid Caustic Soda, Methyl Alcohol, Isopropyl Alcohol, Glycol
DSXX-SAX-TXXS-X	Polyvinyl Chloride, Ammonia, Asphalt, Sulfuric Acid, Chromic Acid, Electroplate Solution, High Temperature Sauce, Chili Sauce, Coal Oil, Volatile Oil, Carrier Oil, Immiscible Fluids, Freezing Mixture, Degreasing Agent, Methylene Chloride, Jam, Juice, Acetic Acid, Leavan, Slops, Balsam, Olive Oil, Defoamer
※DSXX-SAX-OXSO-X	Glaze, Pottery Clay Thick Liquid, Bolivian Filament

Note:

- ◆ Depending on the density, temperature, concentration, and fluid production of the liquid, it may not be usable.
- ◆ If it is used for the abrasive fluid, please make sure wear-resisting property.
- ◆ Please inquiry with us directly about other liquids, if this information is above-unmentioned.
- ◆ Please see the type-specification comparison.
- ◆ Please inquiry to us about the type-specification noted “※” advance.



Important

Read these instructions completely, before installation and start-up. It is the responsibility of the purchaser to retain this manual for reference. Failure to comply with the recommendations stated in this manual will damage the pump and void the factory warranty.



II 2 GD c IIB T4~T5

II (Explosive atmospheres, like flammable gases or dust.)

2 (Protection level: exist it during operation, in explosive gas>10~1000hrs)

GD (Dangerous source: gas, dust) c (Explosion-proof structure: Construction safety)

IIB (Explosion-proof electrical equipment classification: B)

T4~T5 (Temperature level: the highest surface temperature is below 100°C~135°C.)



CE marking is a certification mark that indicates conformity with health, safety, and environmental protection standards for products sold within the European Economic Area (EEA). The CE marking is also found on products sold outside the EEA that have been manufactured to EEA standards.



improvement (7) Factual approach to decision making (8) Mutually beneficial supplier relationships.

ISO 9001: 2015 quality management systems. It was published by the International Organization for Standardization. And we base on quality management principles: (1) Customer focus (2) Leadership (3) Involvement of people (4) Process approach (5) System approach to management (6) Continual

MATERIAL AND TEMPERATURE RANGE

Material	Description	Temperature Range
Stainless steel (SUS):	Stainless steel is a family of iron-based alloys that contain a minimum of approximately 11% chromium, a composition that prevents the iron from rusting, as well as providing heat-resistant properties.	-196~800° C
Aluminum alloys (AL):	Aluminum has a high chemical affinity to oxygen, which is an oxide film that can avoid oxidation. It also has excellent corrosion resistance, high electrical conductivity, and thermal conductivity, and is non-flammable and non-toxic.	-230~500° C
Polypropylene (PP):	It is a thermoplastic polymer used in a wide variety of applications. It has good resistance to hit. Polypropylene at room temperature is resistant to fats and almost all organic solvents. Non-oxidizing acids and bases can be stored in containers made of PP. Polypropylene is used in the manufacture of loudspeaker drive units. It is a common polymer material.	-5~100° C
Thermoplastic Urethane (TPU):	Thermoplastic polyurethane (TPU) is any of a class of polyurethane plastics with many properties, including elasticity, transparency, and resistance to oil, grease, and abrasion. Technically, they are thermoplastic elastomers consisting of linear segmented block copolymers composed of hard and soft segments. It has many applications including arms, medical, food industry.	-30~100° C
Viton:	In terms of chemical resistance, fluorinated rubber has excellent corrosion resistance. For organic solvents, inorganic acids, strong oxidants, and greases are superior to other types of rubber.	-25~200° C
Santoprene:	Santoprene thermoplastic vulcanizates (TPVs) are high-performance elastomers, which offer manufacturing flexibility, ease of processing, and durability. It combines the characteristics of vulcanized rubber with the processing properties of thermoplastics.	-40~135° C
Polyethylene (PE):	The thermoplastic resin is made by polymerization of ethylene, which also includes a polymer of ethylene and a small amount of the polyethylene alpha in the industry. It has excellent electrical insulating properties, very low water absorption, and good low-temperature resistance.	-40~80° C
Teflon:	PTFE is used as a non-stick coating. Because of its extreme non-reactivity and high-temperature rating, PTFE is often used as the liner in hose assemblies, expansion joints, and in industrial pipelines, particularly in applications using acids, alkalis, or other chemicals. Its frictionless qualities allow an improved flow of highly viscous liquids, and for uses in applications such as brake hoses.	-190~260° C
Bakelite:	The plastic is made from synthetic components. Its properties made it suited for a much wider variety of purposes. It was resistant to heat and would not conduct electricity, so it was a really good insulator—which made it particularly useful in the electrical industries emerging.	-50~150° C
Ethylene Propylene Rubber (EPDM):	EPM is considered a valuable elastomer due to its useful chemical and physical properties; it is resistant to heat, oxidation, ozone, and the weather and it is also not susceptible to color loss.	-40~138° C
Nitrile Rubber (NBR):	It is a synthetic rubber copolymer of acrylonitrile (ACN) and butadiene. NBR has good resistance to oils, ordinary diluted acid, and alkali. The black NBR rubber (containing carbon black) has excellent antistatic properties. But, when it is attached to ultraviolet and ozone environments, it will be getting brittle. (Disadvantages for outdoor working) It is suitable for work and energy-intensive processing. (vulcanization, hardening)	-40~100° C

Annotation: The temperature range above for reference only. The exact situation should consider the influence of environmental conditions and external forces.



Important

Read these instructions completely, before installation and start-up. It is the responsibility of the purchaser to retain this manual for reference. Failure to comply with the recommendations stated in this manual will damage the pump and void the factory warranty.

NO.	Component Name	Amount	ComponentNO.	NO.	Component Name	Amount	ComponentNO.
1-1	HexagonScrew	16	PC000019SW	45	HexagonScrew	8	PC000013SW
1-2	HexagonScrew	8	PC000106SW	#46	Oring	2	PD000012
1-3	Ping Hua Division	24	PC000067	47	HexagonScrew	12	PC000028SW
2	HexagonScrew	8	PC000116	49	Pipe	2	PA000124
&4	DownBallSeat(S)	2	PA000019	50	Silencer	1	PB000049
-	DownBallSeat(PP)	2	PB000115	51	AirpressureRoomOfPump	2	PA000196
#5	Teflon Oring	4	PB000016	52	ThimbleCover	2	PA000169
&6	UpBallSeat(S)	2	PA000030	&53	SitheryMassValve	1	PB000068N
-	UpBallSeat(PP)	2	PB000116	&54	IncludePly	1	PB000089
&7	UpBallCover(S)	2	PA000034	55	PipeAdapter	2	PA000218
&9	Ball(Bakelite)	4	PB000204	#56	AbnormalOring(inside)	1	PD000129
-	Ball(Teflon)	4	PB000042	#57	AbnormalOring(outside)	1	PD000130
-	Ball (SUS)	4	PA000007	#58	Oring	2	PD000003
#10	Teflon Pad	2	PB000094	#59	Oring	4	PD000002
11	HousingOfPump	2	PA000046N	&60	SwitchThimble	2	PA000153S
12	SteelHexagonScrew	2	PC000175				
13	SteelWasher	2	PC000060				
&14	PadOfDiaphragm	2	PA000066N				
&15	Diaphragm	2	PD000041N				
17	PadOfDiaphragm	2	PA000057				
#17-1	Oring	2	PD000054				
#18	Oring	2	PD000031				
19	ShaftCover	2	PB000180				
#20	Oring	2	PD000008				
#21	Oring	2	PD000019				
&22	ShaftOfDiaphragm	1	PA000085				
&24	BodyOfSquareSwitch	1	PA000111				
&25	SwitchPiston	1	PA000144				
#26	Oring	3	PD000002				
#27	Oring	3	PB000250				
#28	Oring	2	PD000016				
29	HexagonScrew	2	PC000209				
30	CapNut	2	PC000167				
&31	C-shapedRetaining	2	PA000069				
32	HexagonScrew	4	PC000032SW				
#33	Oring	1	PD000050				
#34	Oring	1	PD000015				
&35	BodyOfSequential	1	PA000152				
&36	PistonOfAirValve	1	PA000140				
#37	Oring	1	PDAP0032				
#38	Oring	2	PDAP0022				
&39	StartingCopperLatch	1	PA000153				
40	CoverOfSequentialB	1	PB000102				
41	CoverOfSequentialA	1	PB000079				
#42	Oring	1	PD000002				
43	HousingOfSequential	2	PB000139				
44	BodyOfCylinderBase	1	PA000093				

("#"SPARE SEAL)
("&"Consumptive Parts Possible)

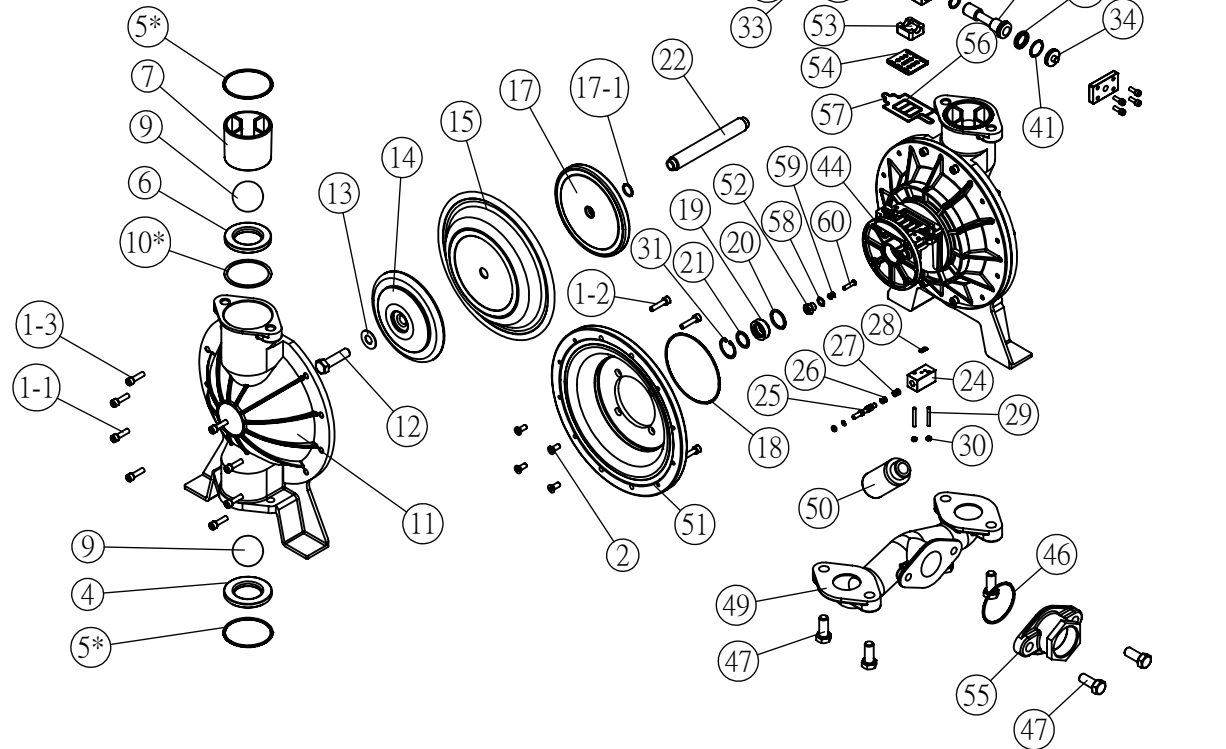

(*None of this part in some model)

2017/12

DS20-SAT-OXXX-01

Dissolution drawing

SCREWS TORQUE GUIDE

Position	Name	Torque Values(kgf.cm)
#45	M6 Hexagon Screw	50~55(Max)
#12	M16 Steel Hexagon Screw	1120~1150(Max)
#2	M8 Hexagon Screw	85~95(Max)
#1-1-2	M8 Hexagon Screw	260~300(MAX)
#32	M6 Hexagon Screw	40~60(Max)
#47	M16 Steel Hexagon Screw	1440~1460(MAX)

Annotation: Please lock it according to the torque value to avoid leakage or over-tightening.

Tension to Torque Conversion

Unit	SI		Gravity Unit			Imperial Unit	
	N.m	CN.m	gf.cm	kgf.cm	kgf.m	lbf.in	lbf.ft
1 N.m		100		10.19	0.1019	8.852	0.7375
1 gf.cm	9.80E-05	0.00981		0.001	0.00001	0.00868	7.20E-05
1 kgf.cm	0.0981	9.81	1000		0.01	0.868	0.072
1 kgf.m	9.8066	981	100000	100		86.8	7.233
1 lbf.in	0.113	11.3	1150	1.152	0.0115		0.083
1 lbf.ft	1.355	136	13800	13.83	0.138	12	



Important

Read these instructions completely, before installation and start-up. It is the responsibility of the purchaser to retain this manual for reference. Failure to comply with the recommendations stated in this manual will damage the pump and void the factory warranty.

DIMENSIONS

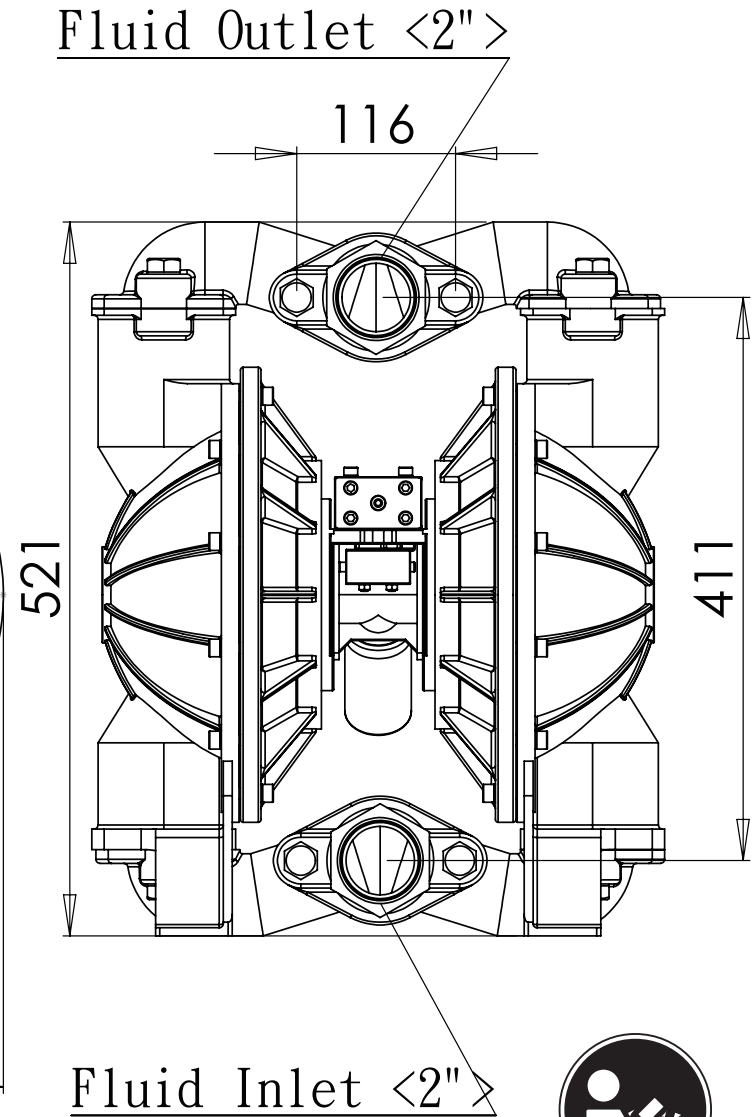
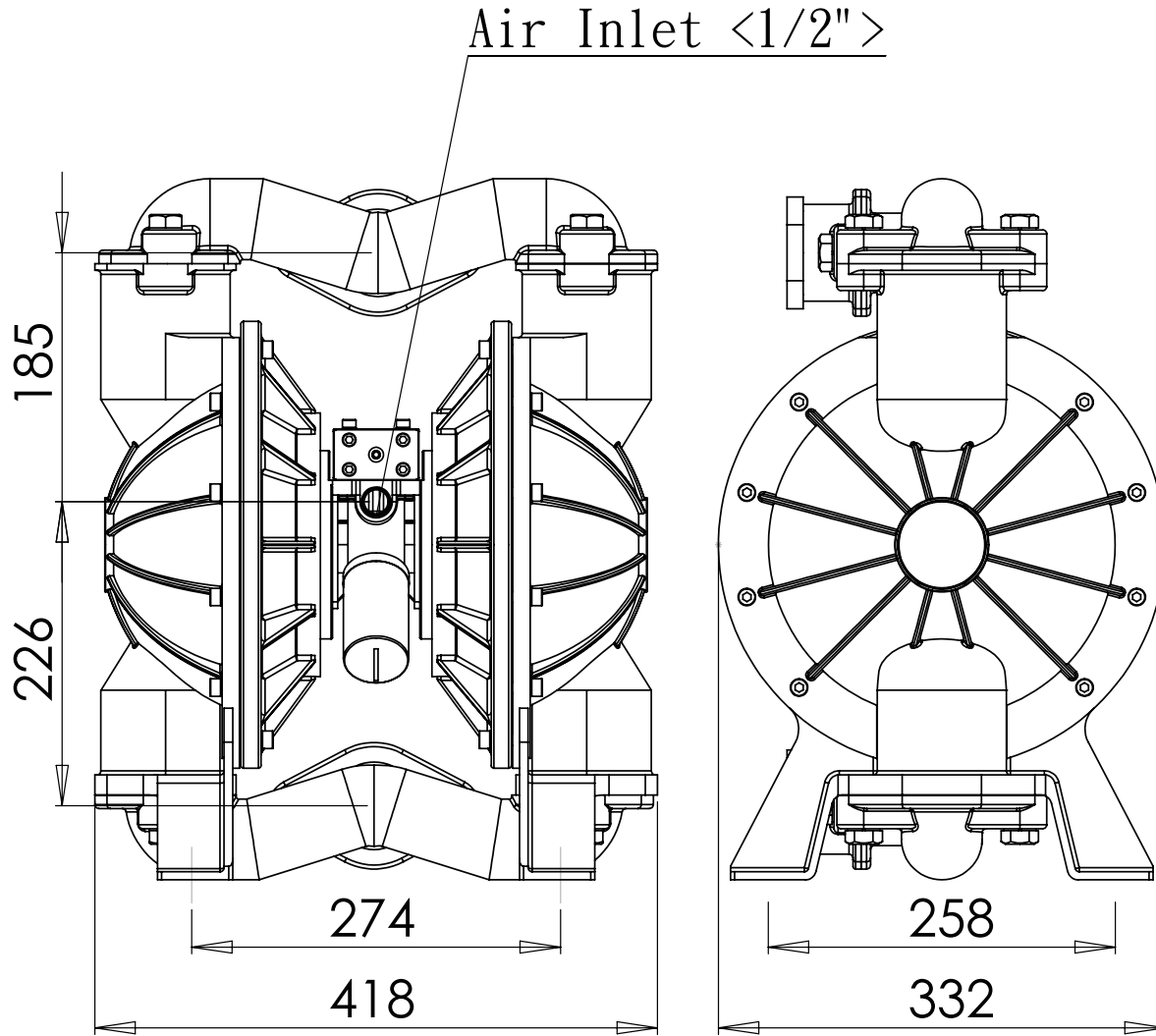

Important

Read these instructions completely, before installation and start-up. It is the responsibility of the purchaser to retain this manual for reference. Failure to comply with the recommendations stated in this manual will damage the pump and void the factory warranty.

IMPORTANT SAFETY INFORMATION



WARNING

When used for toxic or aggressive fluids, the pump should always be flushed clean before disassembly



WARNING

Airborne particles and loud noise hazards. Wear ear and eye protection.



WARNING

In the event of a diaphragm rupture, pumped material may enter the air end of the pump, and be discharged into the atmosphere. If pumping a product that is hazardous or toxic, the air exhaust must be piped to an appropriate area for safe disposition.



WARNING

Before maintenance or repair, shut off the compressed air line, bleed the pressure, and disconnect the airline from the pump. The discharge line may be pressurized and must be bled of its pressure.



WARNING

Before pump operation, inspect all fasteners for looseness caused by gasket creep. Re-torque loose fasteners to prevent leakage. Follow recommended torques stated in this manual.



WARNING

This pump is pressurized internally with air pressure during operation. Always make certain that all bolting is in good condition and that all of the correct boltings are reinstalled during assembly.



Important

Read these instructions completely, before installation and start-up. It is the responsibility of the purchaser to retain this manual for reference. Failure to comply with the recommendations stated in this manual will damage the pump and void the factory warranty.

INSTALLATION CONSIDERATIONS

Installation and Assembly Considerations

- ◆ Connect the suction and discharge ports of the pump with a hose or flexible pipe to avoid damage caused by vibration of the pump. Never step on the diaphragm pump or use other methods to apply weight to the pump body, or suspend the pump. Otherwise, there is a danger of personal injury or equipment failure.
- ◆ The suction head of the inlet should be less than six meters (For water).
- ◆ The direction of the pipe (inlet and outlet) can be turned, but please pay attention to the O-ring when disassembling and installing it and locking the pipe well to prevent leakage.
- ◆ We suggest that you can install the air filter, regulator, and lubricator (FRL) on the air inlet of the pump.

Adjustments for connection of high air pressure

- ◆ The air source of the air compressor is connected to the air inlet of the pump through the air pressure hose. It is operated by the air filters. The supply air pressure used shall not exceed the maximum operating pressure.
- ◆ We suggest that you can install the air regulator on the air inlet of the pump. The supply air pressure used shall not exceed the maximum operating pressure.
- ◆ Check the air filter at the air pressure input regularly to drain the accumulated wastewater and impurities. If too much wastewater is introduced into the pump body, the wastewater and lubricating oil will emulsify and affect the lubrication of the parts, or block the pores, thereby affecting the operation performance of the pump or causing malfunction.

Air Line Moisture

- ◆ Water in the compressed air supply can create problems such as icing or freezing of the exhaust air, causing the pump to cycle erratically or stop operating. Water in the air supply can be reduced by using a point-of-use air dryer to supplement the user's air-drying equipment. This device removes water from the compressed air supply and alleviates the icing or freezing problems.

Air cycle

- ◆ To start the pump, the air compressor provides air pressure to the body of the cylinder base of the pump, flowing into the Sequential and Air Valve through the air hole. It drives the diaphragm and shaft doing power conversion. During the conversion process, the deflated gas is discharged through the silencer. Please make sure that the exhaust gas pipeline is smooth to avoid the blockage of the pump.

Liquid delivery process

- ◆ When the pump is used for materials that tend to settle out or solidify when not in motion, the pump should be flushed after each use to prevent damage. (Product remaining in the pump between uses could dry out or settle out. This could cause problems with the diaphragms and check valves at the restart.) In freezing temperatures, the pump must be completely drained between uses in all cases.



WARNING

Before maintenance or repair, shut off the compressed air line, bleed the pressure, and disconnect the airline from the pump. The discharge line may be pressurized and must be bled of its pressure.



Important

Read these instructions completely, before installation and start-up. It is the responsibility of the purchaser to retain this manual for reference. Failure to comply with the recommendations stated in this manual will damage the pump and void the factory warranty.

INSTALLATION INSTRUCTIONS

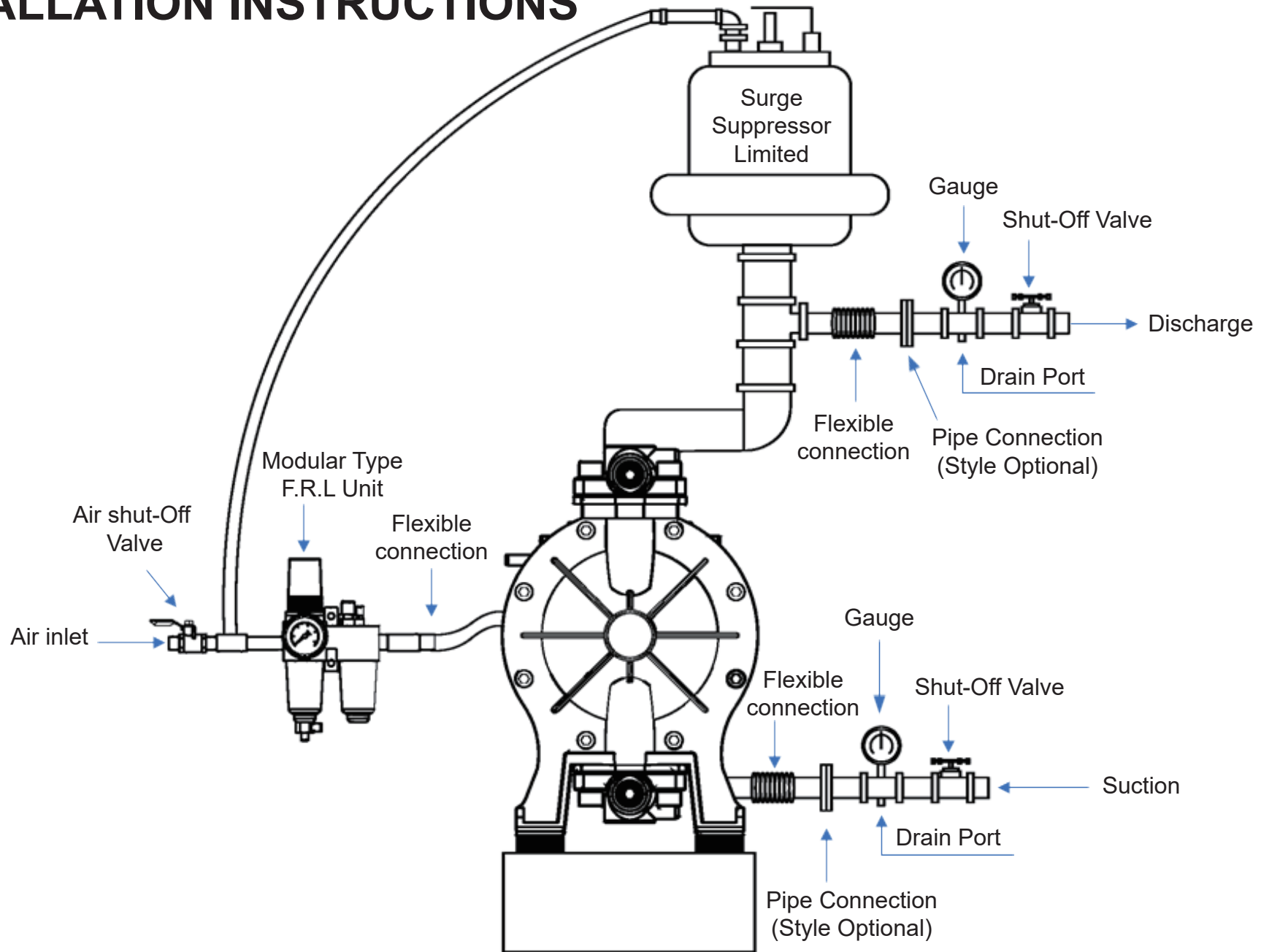

FAQ

A. If your pump won't start.

- a. Air inlet unusual: Check the air regulator whether works or not. If it can't work, change the abnormal parts.
- b. Pipeline clogging: Check the fluid pipe whether blocks or not. If it blocks, removing the obstruction. (Make sure the pipe is relieved air pressure to prevent casualty.)
- c. Damaged parts: If the parts of the pump have damaged, please contact a professional person.

B. Air entrainment in the pipe

- a. Loose joints: Check the input pipeline whether close tightly.
- b. Diaphragm problem: The diaphragm loose or ruptured might lead air escape to the pipeline, please contact a professional person.

C. Fluid leaks from pump exhaust

- a. Condensation: If it leaks oil-water mixture from the silencer, not the liquid which transports. It should enhance the air pressure pipeline and install the modular type F.R.L unit.
- b. Diaphragm problem: If it is the liquid being transported, the diaphragm may be loose or ruptured. Please contact a professional person.

D. Pump flow rate dropping or it is irregular working.

- a. Ball valve abnormal: If the ball valve has severe wear parts or include foreign objects, it might cause a ball valve abnormal. Please change the parts or remove the foreign object.
- b. O-ring abnormal: If the O-ring wear and tear, it might lead to air pressure unbalanced. You can purchase spare seal kits by yourself to exchange the broken O-ring.

E. The pump works to slow down or stall easily.

- a. Pipeline stuck: Make sure whether the inlet/outlet pipelines blocked or not. It might cause the inner pipeline to get smaller. We recommend you to clean up or change the pipeline.
- b. Abnormal lubrication: Ensure the air chamber of the pump whether lubricates sufficient or not. Please clean up the dirty parts and relubrication. (It is recommended to add lubricating oil to the air pressure inlet pipeline every half year, don't exceed 10ml each time.)
- c. Sequential valve abnormal: If the deterioration of the sequential, if it is worn, please change it.
- d. Compressed Air Lines Freezing: The Slithery Mass Valve #53 might be frozen because of low temperature and condensate. If it happens, it is recommended to add antifreeze in the pipeline and enhance the air-drying to improve the situation.
- e. Clogged Silencer: If the air quality in the environment is horrendous, it may cause the air pressure source to mix dust. When it happens, it will block the silencer hole, which will cause unsatisfactory exhaust after a while. It is suggested that replace the new or a larger aperture silencer.

F. Air leakage

- a. The Slithery Mass Valve #53 and Include Ply #54 are worn: If the Slithery Mass Valve #53 and Include Ply #54 are worn. It will have occurred air leakage which will cause the pump to operate abnormally. If it happens, please replace the part.
- b. O-ring is worn: If the O-ring inside the Body of Sequential to Air Valve is worn. It will have occurred air leakage which will cause the pump to operate abnormally. Please replace the O-ring.

G. There is an abnormal leak at the pump junction

- a. Air pressure is overload: Pump operating pressure cannot more than 8.3 bar (kg/cm²). If it exceeds, it will cause the liquid leakage or damage of the pump, it should adjust the air pressure range.
- b. The joint is loosely sealed: Except incomplete locking, if the O-ring or Pad of the pump joint has deformation or wear, it will be loosely sealed and then leakage. Please replace the parts of the pump.

S. If these answers cannot solve your problem, please contact DYI SHENG's staff.

Warranty:

Please look at "F. Warranty Instructions".



Important

Read these instructions completely, before installation and start-up. It is the responsibility of the purchaser to retain this manual for reference. Failure to comply with the recommendations stated in this manual will damage the pump and void the factory warranty.

WARRANTY INSTRUCTIONS



Warranty Instructions

- ◆ We are guaranteed against the quality of the pump for a period of one year from the date of the shipping date.
- ◆ We could change a new one for free in seven days, in the case of the new product hardware failure itself rather than human damage.
- ◆ We will charge the material cost and repair fees for products out of warranty.
- ◆ It is excluded product delivery fees.
- ◆ Pumps returned for warranty which can't repair because of the original quality of the product, we will change a new one for you.



Warranty Exceptions

- ◆ Improper use (e.g. Falling, Attacked, Liquid input...etc.) or abnormal operating conditions (e.g. Flood, Fire, Earthquake, Lightning strike, Typhoon...etc.) these damages are not covered by the warranty.
- ◆ Improper installation, self-modifying, wear and tear caused by not transporting in accordance with machine regulations.
- ◆ Accident or defect caused by negligence.
- ◆ Failure caused by additional equipment.
- ◆ Repair by the non-original or authorized repair center.
- ◆ The product serial number does not match or the damage to no clear.
- ◆ The normal damage caused by the mutual abrasion between the fluid transportation process with the parts.